



CLASS40

2019 CLASS RULES

Index

Changes for 2019 (following the EGM)

Index	2
Fundamental Rules	3
Chapter 1 – General characteristics	5
100 – General remarks	5
101 – Appendages	6
102 – Rigging	6
103 – Sails	7
104 – Interior fittings	8
105 – Hull construction standards	8
Chapter 2 – Dimensions	9
200 – Dimensions	9
201 – Measurement trim	9
202 – Hull length (Lh)	9
203 – Maximum beam (Bmax)	9
204 – Maximum draft (Tmax)	10
205 – Average freeboard	10
206 – Displacement	11
207 - Ballast	11
208 – Mast (Highest point)	12
209 – Boom and mainsheet traveller track	12
210 – Bowsprit	12
211 – Spinnaker pole	13
212 – Sails	13
213 – Geometry of the hull	15
214 – Geometry of the deck	15
215 – Bow volume	16
Chapter 3 – Safety	17
300 – Stability	17
301 – Displacement conformity	17
302 – 90° test	17
303 – Watertight bulkheads	18
304 – Combined volume of the deck camber and the coachroof	18
305 – Buoyancy volumes	18
306 – Propulsion	19
309 – Lifelines	19
Chapter 4 – Cost limitation	20
401 – Hull, deck, interior structure and fittings	20
402 – Stanchions, pulpits and pushpits	20
403 – Rudders and steering system, keel fin	20
404 – Mast, boom, spinnaker pole, bowsprit	21
405 – Lateral standing rigging	21
406 – Equipment	21
407 - Electronics	22

FUNDAMENTAL RULES

These rules apply to monohull yachts with the aim of racing offshore in real time.

A monohull is a boat with a single flotation plane at rest or under sail, whose hull depth in any transversal section shall not decrease towards the centreline.

The current World Sailing (RRS, ERS and OSR) rules apply.

The Rules for Class 40 Monohulls are the open type set out in Paragraph C.2.3 of the ERS (Equipment Rules of Sailing), meaning that anything that is not explicitly forbidden, limited or imposed, is permitted.

The Class40 association was formed with the aim of creating a fleet of simple, seaworthy, performance-oriented, ocean-racing yachts, and where possible within a limited budget. These Class Rules aim to fulfil this mission, but no text can anticipate the capacity of human intelligence to exploit the meaning of words in a manner not in line with the original aim of these Rules.

For this reason, it is highly recommended that any questions on the interpretation of these Rules which might be contrary to the spirit of the Class be put first to the Executive Committee, to avoid the risk of being considered outside the Rules.

Prior to each new build, detailed draft drawings including the structural elements and materials to be used shall be submitted to the Class Measurer. The layout and distribution of corrector weights must feature in the draft drawings. The submission of these drawings is a requirement for the allocation of a Class40 number.

The official language of the class is French.

Class 40 monohulls are destined for offshore competition.

Skippers should note that sailing is a potentially dangerous activity, and that the decision to race is theirs alone, in accordance with Article 4 of the RRS.

The safety of the boat and its crew is the inalienable responsibility of the owner, or his/her skipper, who must ensure that the yacht is in perfect condition, thoroughly seaworthy, and that it is crewed by an experienced crew, who have undergone the appropriate training and are physically capable of dealing with bad weather.

In accordance with article 3 (c) of the RRS and whatever the circumstances of an accident, no legal responsibility can be sought from any of the following parties: World Sailing, National Authorities (FFVoile), Class 40, or an official measurer of the present rules.

The class must respect the conditions of the Advertising Code in Category C of the World Sailing Regulations (Chapter IV; 20).

Production and prototype Class40s shall share a common ranking.

The results of the 90° test and the weight of boats can be consulted at the class secretariat.

All boats without exception may be the subject of random scrutineering (where a boat does not conform, the measurement expenses shall be paid by the person responsible for that boat).

Any modification having a bearing on the Rules shall be brought to the attention of the Class Measurer and of the Class secretariat.

A disabled sailor in Class40 may request that a specific dispensation be considered.

CHAPTER 1 - GENERAL CHARACTERISTICS

100. GENERAL REMARKS

The boat must comply with all aspects of:

- the “NF EN ISO 12217 Small Craft- Stability and Buoyancy Assessment and Categorisation - part 2: Sailing boats of hull length greater than or equal to 6m” for design category A, except 6.1.4 b) where the sentence “*for the next less demanding design category*” is replaced by “*for the design category concerned*” ;
- the “NF EN ISO 11812 – Small Craft – watertightness requirements of quick draining cockpits” for design category A ;
- as well as the requirements set out in OSR for Category 1, with the exception of chapter 3.09 (cockpit).
- Requirement 12215 of (OSR 3.03.1)

In the event of conflict between the OSR and the NF EN ISO 12217 standard, the latter will prevail.

These rules are modified as follows:

- ISO 12217-2 :
 - ◆ 6.3.2 “Alternative requirement for categories A & B” does not apply. See §301 of these rules.
- OSR Cat 1:
 - ◆ 3.03.2 b) Certification by a notified body does not apply.
 - ◆ 3.04 Stability index does not apply
 - ◆ 3.08.03 “Companionway” does not apply, replaced by the restrictions noted in the ISO 12217-2 standard: §6.2.2.2
 - ◆ 3.14 “Pulpits, Stanchions, Lifelines”, modified, see §402 of these rules.
 - ◆ 3.19.1 “Bunks”, modified, see §104 of these rules.
 - ◆ 3.21.1 “Drinking water”, see §104 of these rules.
 - ◆ 4.01.2 “Sail letters & numbers”. As defined in Chapter 3 of the Appendix to Class Rules
 - ◆ 4.26.2a “Heavy-weather jib”. Modified, see §212.04 of these rules.
 - ◆ Appendix H “Organisation of Oceanic Races”. Does not apply.
- RRS:
 - ◆ § 50.4 “Headsails”, modified. See §212.03.01 of these rules.
 - ◆ § 51. “Movable ballast”. Does not apply.

- ◆ RRS 52 MANUAL POWER: does not apply to liquid ballast

101. APPENDAGES

The external appendages are limited to a single fixed keel when sailing and a maximum of two movable appendages. For example, a trimtab, interceptor or flap are considered to be moving appendages.

Only one configuration of appendages is permitted per full 12 month period.

No modification to the keel position is permitted within a period of less than 12 full months.

Note: daggerboards are forbidden

102. RIGGING

102.01 – General provisions

Stays, backstays, runners and shrouds (permanent and temporary) must be fixed to the chainplates situated inside the natural intersection of the hull and deck extension.

A tolerance of 20 mm is acceptable for attached chainplates.

The forestay must be of a fixed length, neither removable nor adjustable while sailing and attached to the upper quarter of the mast.

All systems for adjusting the position of the mast base, including a mast jack pump, are forbidden while racing.

Deck spreaders are forbidden.

102.02 – Mast rotation

Rotating masts are forbidden.

102.03 – Mast cant

Canting a mast is forbidden.

103. SAILS

103.01- General provisions

The total number of sails on board is limited to 8.

Within this total of 8 sails, boats are required to carry the following:

1 mainsail, 1 solent, 1 heavy-weather jib, 1 storm jib, and 1 storm trysail if the luff of the mainsail cannot be reduced by more than 70% when fully reefed.

Only sails which have been declared before the start may be used in a race.

All materials other than woven or laminated polyester and nylon (modulus lower than 300g/denier) are forbidden in the manufacture of other sails, with the exception of two sails and the heavy-weather jib which can be made from any material

Carbon battens and carbon batten pockets are forbidden.

103.02 – Definition of sails

103.02.01 Mainsail

Sail attached to the back of the mast

103.02.02 Solent

Triangular sail flown from the fixed forestay. The solent cannot be manufactured with a structural luff.

103.02.03 Heavy-weather jib

Triangular headsail whose surface area is limited to 32 m² (surface = luff x LP/2). This sail must be designed to go upwind in heavy weather.

103.02.04 Storm jib

Headsail as specified by OSR.

103.02.05 Storm trysail

Heavy weather sail as specified in the OSR.

The trysail must be manufactured from a minimum material weight of 9oz.

104. INTERIOR FITTINGS

In addition to OSR Category 1 requirements, there must be on board:

- A minimum of 4 permanently installed solid berths (articulating berths not included) which measure a minimum of 1.8m x 0.5m in size;
- A minimum of two portlights in the coachroof providing lateral visibility, the area of visibility measuring a minimum combined area of 0.2m², not including the companionway hatch, on a vertical plane at 0° of heel;
- Permanently installed and usable head;
- Fixed water tanks containing a combined minimum of 40l. These tanks shall be situated at less than 500 mm from the centreline of the boat.

Tanks are not permitted in the keel fin (dispensation for boats launched prior to the 1st of January 2012).

105. HULL CONSTRUCTION STANDARDS

Any boat designed after the 1st of January 2010 must provide a letter to Class40 certifying that parts 5, 8 and 9 of ISO 12215 have been respected, as defined in OSR 3.03

CHAPTER 2 – DIMENSIONS

200. DIMENSIONS

The dimensions that must be measured in compliance with the NF EN ISO 8666 standard are indicated by the name EN/ISO 8666 followed by the relevant chapter.

201. MEASUREMENT TRIM

Measurement trim for measuring purposes is the Light Craft Condition LCC (in conformity with 6.3 of the EN ISO 8666 standard and 3.5.1 of the EN ISO12217-2 standard) excluding anchoring equipment (anchor, chain and warp) and the loose external equipment (fenders, warps, mooring lines), sails, liferaft and batteries (except for the dedicated engine starting battery (OSR 3.28.3) measuring a maximum capacity of 60 Ah at 12 volts).

Fixed internal fittings, be they for comfort or safety, such as fridges, watermakers, plumbing or other equipment which are included when the boat is weighed, shall not be removable and shall be listed on the measurement certificate, including their location. The same applies to all other fixed navigational equipment, such as autopilots, computers etc... Any fixed equipment or interior fitting with a (some) degree(s) of movement whose weight exceeds 5 kg shall be excluded from measurement trim, unless the centre of gravity of the item is never further than 200 mm from the centreline of the boat.

202. HULL LENGTH (L_h): (EN/ISO 8666 5.2.2)

The hull length shall not exceed 12.19 m.

Reminder: This measurement does not include rudders and their fittings, bobstay fittings, without devices designed to lengthen the waterline, nor pulpits and pushpits, solar panels and wind vanes, nor the bowsprit, if it is removable (dispensation for fixed bowsprits of boats launched before the 31st of January 2007).

In the case of transom-hung rudders, no part of the rudder system shall be wider than 150 mm, except for the top of the rudder boxes and the top of the rudders.

203. MAXIMUM BEAM (B_{max}): (EN/ISO 8666 5.3.2)

The maximum beam must not exceed 4.50m.

204. MAXIMUM DRAFT (T_{max}): (EN/ISO 8666 45.4.4.1)

The maximum draft must not exceed 3.00m in measurement trim.

205. AVERAGE FREEBOARD

The average freeboard must not be lower than 1.08 m in measurement trim.

The average freeboard is obtained by dividing by 8.19 the vertical projected surface of the topsides between 2m from the forward-most point of the hull used to measure L_h (point A) and 2m from the aft-most point of the hull used to measure L_h (Point B).

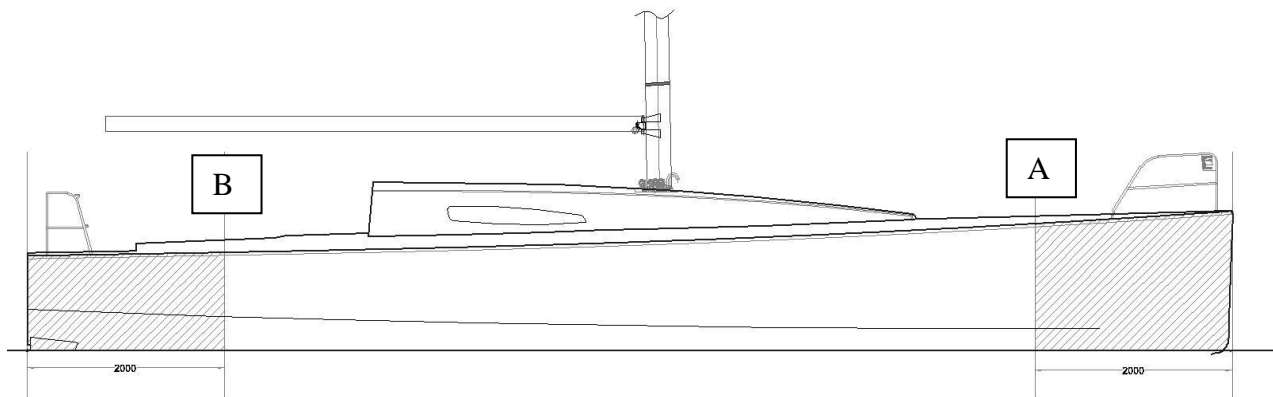

The topsides are defined as the hull surface between the waterline and the sheer.

The sheer is defined as the intersection between the hull and deck as per the drawings below. **For any configuration which is different, the Technical Committee must be consulted for an interpretation.**

At point A, the freeboard cannot be less than 1.25m and no point of the sheer forward of point A can be lower than A. Interruptions in the sheerline are permitted for a sprit recess for a bowsprit, but not extend lower than 1.25m from the waterline, no more than 1m aft of the forward-most point of the hull.

Between points A and B, the sheer must not feature any inflection point or discontinuity in its curve.

From 1m aft of the stem to 0.5m forward of the stern, the sheer must be a continuous line with a minimum radius of 2m in the profile view.

(Dispensation for boats measured prior to the 1st of January 2014).

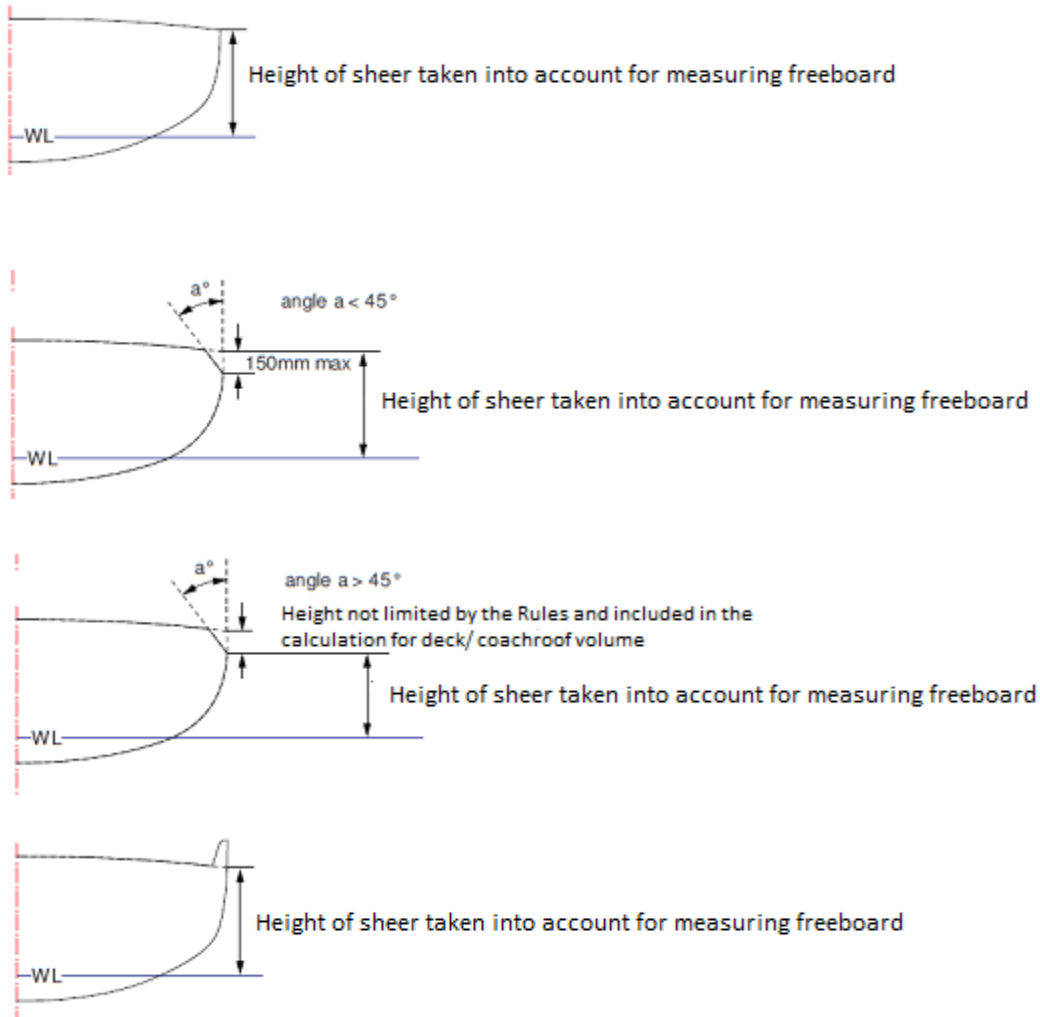

206. DISPLACEMENT

The boat weight must not be lower than 4500 kg in measurement trim as defined in 201.

The pre-build detailed draft drawings must show the position of any potential corrector weight (See Fundamental Rules).

207. BALLAST

The maximum volume of liquid ballast is 1500 l, symmetrically distributed (750 l on each side), including plumbing up to the centreline of the boat. The ballast tanks are fixed.

208. MAST (Highest point)

A band measuring a minimum of 25mm in width in a contrasting colour must be affixed around the top of the mast. The lower part of this band will be situated at a height of 19 m above the water surface in measurement trim. No point of any set sail may be situated above the lower part of this band.

Halyards which exit above the point of maximum air draft must be routed/restrained by appropriate means, for example:

- fairlead
- strop
- some form of mechanical stop for the headboard car

In the absence of such a band, the high point will be the highest point of the mast tube.

209. BOOM AND MAINSHEET TRAVELLER TRACK(S)

The aftermost part of the boom must be at least 80cm forward of the aftermost point used to determine Lh, whatever the trim of the mainsail.

Any track with a curve(s) where the radius is less than 4.5 metres is forbidden.

No part of the mainsheet traveller track can be further than 1.25 m from this aftermost point (dispensation for boats launched prior to the 31st of January 2007).

210. BOWSPRIT

Once in position, the forward extremity of the bowsprit must not exceed the forward-most point used to determine Lh by more than 2.0 m. The mounting system must ensure that this length of 2 metres shall never be exceeded.

The bowsprit must be removable (in line with EN/ ISO 8666 §5.2.2 for measuring length Lh).
(Dispensation for boats launched prior to the 31st of January 2007).

210.01 Outrigger

Outriggers whose purpose is to hold the spinnaker guy outboard to windward are permitted.

These cannot be located more than 35% of Lh from the bow.

Outriggers are subject to the same material limitations as spars.

Exemption on their position for boats equipped with outriggers before the 1st of January 2012.

211. SPINNAKER POLE

Once in position, the forward extremity of the pole must not exceed the forward-most point used to determine Lh by more than 2.0 m.

212. SAILS

The surface area, mainsail + solent (see definition in 212.03.01), must not exceed 115 m².

212.01 - Reminders and general points

212.01.01 – The Equipment Rules of Sailing (ERS) and dispositions in Appendix G of the World Sailing RRS rules (size and positioning of the sail numbers) apply.

212.01.02 - Sail numbers are distributed by the Class 40 in chronological order of requests.

212.02 - Mainsail measurement

212.02.01 - The sail area of the mainsail (SMGV/MMSS) is calculated by the formula:

$$\text{SMGV/MMSS} = \frac{\text{Luff} \times (\text{HB} + 2 \times \text{MGT} + 3 \times \text{MGU} + 4 \times \text{MGM} + 4 \times \text{MGL} + 2 \times \text{foot})}{16}$$

212.02.02 - Height

Luff (ERS G.7.3)

212.02.03 - Girth

- ◆ HB is the girth of the mainsail head (ERS G.7.8)
- ◆ MGT, is the upper girth (ERS G.7.7).

Definition: The upper point of the leech is the point on the leech that is equidistant from the halyard point and the three quarter way point.

- ◆ MGU is the girth at the three quarter way point (ERS G.7.6).
- ◆ MGM is the girth at the middle distance point (ERS G.7.5).
- ◆ MGL is the girth at the quarter distance point (ERS G.7.4).

212.02.04 - Foot

Foot (ERS G.7.1).

212.02.05 - The distance between the mid-foot point and the equidistant point between the tack point and the clew point shall not exceed 0.15 m. (ERS G.5.6.a)

212.03 - Measurement of the genoa/jib/solent

212.03.01 - A genoa/jib/solent is a triangular shaped foresail hoisted along a stay.

A genoa/ heavy-weather jib/ solent is a headsail which is defined as a sail whose half width is measured from the half leech point to the closest point on the luff, and where this half width is 50% or less of LPG and whose width perpendicular to the luff at the three quarter leech point is less than or equal to 30 % of LP.

The head width (HHB) is less than or equal to 45 cm.

.

212.03.02 - LP is the luff perpendicular (ERS G.7.11).

JL is the luff length (ERS G.7.3).

212.03.03 - The surface area of the jib (SMF) is given by:

$$SMF = 0.5 \times JL \times LP$$

The distance between the mid-foot point and the equidistant point between the tack point and the clew point of the genoa/ jib/solent shall not exceed 0.1 m. (ERS G.5.6.a)

212.04 - Trysail, heavy-weather jib and storm jib

Refer to 4.26 of the OSR Category 1 modified as follows:

A reef is permitted in the heavy-weather jib.

212.05 - Certificate of sail conformity

The sail maker shall sign a document (supplied by the Class 40) certifying the sail materials, measurements and surface area of the mainsail and each genoa/jib/solent and heavy-weather jib, as well as their total conformity with the specifications of the RRS and ERS.

213. GEOMETRY OF THE HULL

From 150mm under the sheer, any point vertically below must be closer to the centreline than the point immediately above, no matter which section.

214. GEOMETRY OF THE DECK

The cockpit can be any width between the aft-most point used to determine Lh and 1.75 metres forwards of this point.

Between 1.75 m and 4.50 m forward of the aft-most point used to determine Lh, no part of the deck or cockpit surface below the waterline + 300 mm, when the boat is heeled to 90°, can be lower than the sheer of the same section when the boat is floating upright.

Between 4.50 m forward of the aft-most point used to determine Lh and the bow, no part of the deck or coachroof can be lower than the sheer of the same section, with the exception of an anchor locker. The aft-most point of the anchor locker shall be less than 1.50 metres from the bow, and its total volume less than 0.4m³.

Between 1.75m forward of the aft-most point used to determine Lh and the bow, no non-watertight locker may be installed in such a way that it would be below the waterline + 300 mm when the boat is heeled to 90°.

Conformity of deck geometry will be checked during the 90° test.

Any device not covered in this article which could be beneficial for the 90° test shall be submitted to the Technical Committee for an interpretation.

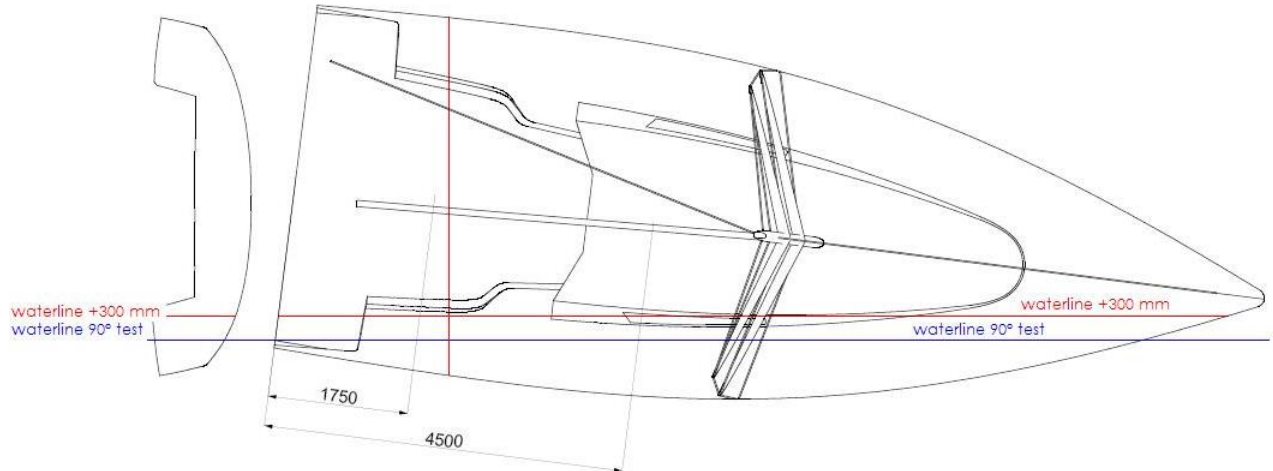

215. BOW VOLUME

The maximum width 200 mm aft of the forwardmost point used to determine Lh shall not exceed 450 mm. Viewed from above, there can be no inverted curve in the sheer. Such that when viewed from above, the sheer between the bow and max beam:

- Shall not feature any concavity,
- The angle between the tangent to the sheer and the centreline of the boat can only decrease.

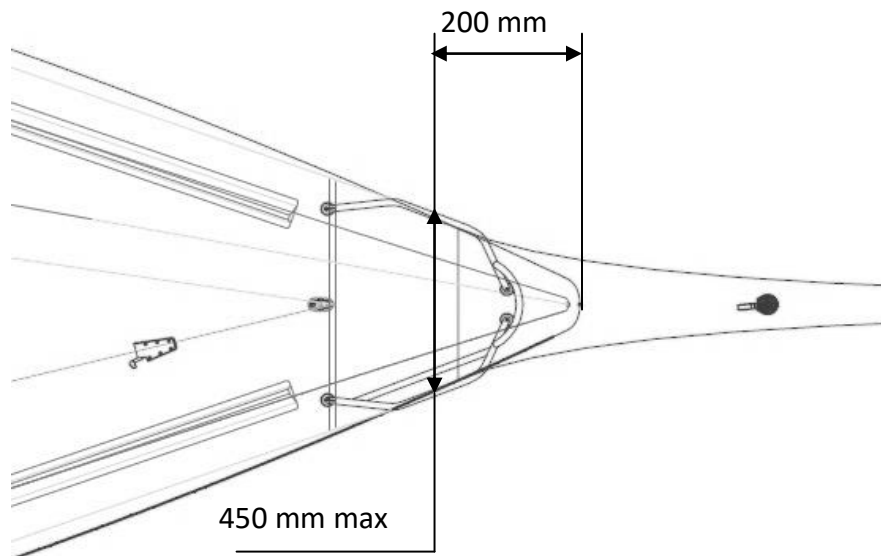

CHAPTER 3 - SAFETY

300. STABILITY: (EN/ISO 12217)

Reminder:

The boat must conform with all aspects of:

- the “NF EN ISO 12217 Small Craft - Stability and Buoyancy Assessment and Categorisation- part 2: Sailing boats with a hull length greater or equal to 6 m” for design category A, except 6.1.4 b) where the sentence “for the next less demanding design category » is replaced by « for the design category concerned”,
- the “NF EN ISO 11812 – Small Craft – watertightness requirements of quick draining cockpits” for design category A.

A Class40 accredited measurer shall have verified the load measured during a Class40 90° test. The written report (or any other document) shall then be submitted to the class. This document shall prove that the stability of the vessel concerned has been verified and shall state the results obtained for each of the requirements of the standards.

Displacement is validated by weighing (see chapter 301).

Within the framework of this measurement, the measurer will note down the following measurements on his report: Lh, Bmax, Tmax, average freeboard, top point of the mast, following the procedure supplied by Class 40.

301. DISPLACEMENT CONFORMITY

The weighing of a boat in measurement trim must have been carried out by a Class40 accredited measurer, using a load cell with its valid annual certificate.

This person will supply the class with a report of the weighing session.

302. 90° TEST

This test is aimed at proving that the boat is capable of righting itself from the broached position with empty ballast tanks.

It must be done by a Class40 accredited measurer.

When heeled at 90 degrees (on both sides, if considered necessary) the boat in measurement trim (see §201) is kept in this position with the aid of a strop passed around the mast at the level of the measurement band at the top point

of the mast (see 208 of the present rules). The load exerted on the strop must be a minimum of 235 kg and a maximum of 320 kg.

If the mast band is placed at under 19m of elevation, the load on the strop must satisfy the same righting moment. (The designer must supply the calculations)

The boat is considered to be heeled at 90 degrees when the aftermost points of the sheer line are situated on the same vertical plane.

303. WATERTIGHT BULKHEADS

A watertight collision bulkhead must be installed between 10% and 15% of Lh, aft of the forward-most Lh point. A watertight bulkhead must be installed forward of the rudder stock(s) and a minimum of 1m forward of the aft-most point of Lh.

A system of watertight hatches, with a minimum opening of 0.18 m², shall enable evacuation via the back of the boat when inverted. This hatch must be located on the transom, outside the aft lifelines on any boat launched for the first time after March 1st 2011. All boats shall conform to this rule by the 1st of September 2010 in order to participate in Category 1 races.

304. COMBINED VOLUME OF THE DECK CAMBER AND THE COACHROOF

The minimum volume, measured from the plan passing via the sheer lines (as defined in EN/ISO 8666), must be at least equal to the boat's maximum beam expressed in m³. A coachroof is mandatory.

A certificate signed by the designer, specifying this volume, must be supplied.

305. BUOYANCY VOLUMES

A minimum of 3 m³ of closed-cell foam is required. This volume, divided into a minimum of 4 compartments, must be distributed symmetrically around the boat's centre of gravity. The volume of the sandwich hull lining may be included in this volume of foam (but not the volume of the deck lining, nor that of the bulkheads).

The skipper must supply a file showing the detail and the distribution of the buoyancy volume, signed by the designer, the builder and the skipper.

306. PROPULSION

An engine, **permanently fixed in place**, with a minimum power of 20 kW, with fixed transmission with sail drive or propeller shaft, and a propeller, situated beneath the centreline of the hull, must be installed.

There must be a minimum of 40 mm between the propeller when open, and the hull. The propeller blades may be folding or feathering.

The propeller when open must have a minimum diameter of 360 mm.

The autonomy of the propulsion system shall be equivalent to that provided by a 40 litre tank for a diesel engine, no matter what the power source.

307. LIFELINES

Only metal lifelines are allowed. A lanyard or synthetic rope may be used to secure the ends of the lifeline. Each lanyard must not exceed 100 mm (4 inches) in length.

CHAPTER 4 - COST LIMITATION

The use of titanium and materials denser than the lead is forbidden, except as described in article 406.

401. HULL, DECK, INTERIOR STRUCTURE AND FITTINGS

Materials forbidden in the construction of the hull, deck, the interior structure and fittings are:

- ◆ Carbon fibre
- ◆ Aramid fibre
- ◆ Any fibre where the maximum tensile strength is in excess of 3800 Mpa
- ◆ Sandwich cores: honeycomb cores.

The use of resin pre-preg reinforcements in the construction of the hull, the deck, the interior structure and fittings is forbidden.

402. STANCHIONS, PULPITS AND PUSHPITS

All materials other than steel are forbidden.

403. RUDDERS AND STEERING SYSTEM, KEEL FIN

Forbidden materials are:

- ◆ Carbon fibre
- ◆ Aramid fibre
- ◆ Any fibre where the maximum tensile strength is in excess of 3800 MPa
- ◆ Honeycomb cores.

The 3D milling of metal keel fins and rudder stocks is forbidden.

For boats launched from July 2012 onwards and for rudders with stocks, only solid, turned stocks (having an axis of rotation) and made from one type of metal only are permitted. The types of metal permitted are:

- ◆ 316L
- ◆ 17-4PH
- ◆ F16-PH

- ◆ Alloy 7075

404. MAST, BOOM, SPINNAKER POLE, BOWSPRIT

Forbidden materials are:

- ◆ Carbon fibre with a modulus greater than 245 GPa (certification from the manufacturer obligatory).

405. LATERAL STANDING RIGGING

All materials other than steel are forbidden.

406. EQUIPMENT

406.01: Forbidden materials are only permitted in equipment as a minor and standard part in the parts list of a standard item, mass-produced and sold to the public, features in suppliers' public catalogues with the price listed.

406.02: Coffee grinders are forbidden.

406.03: Batteries shall be exclusively lead (acid or gel)

406.04: Mainsail halyard locks are forbidden.

Halyard lock are permitted for the Storm jib, the Heavy-Weather jib (trinquette) and loose-luff foresails tacked onto the bowsprit (codes, gennakers, spinnakers).

The definition of a halyard lock is any mechanical system designed to hold sails aloft by taking the load off the halyard. This rule does not apply to furling sails with lashings.

No system for keeping sails hoisted shall be situated higher on the mast than 2.25 m above deck level, except for halyard locks permitted in 406.04.

For any device or equipment not cited in this article and (or) not previously validated by the measurers and which could contain materials listed as forbidden, the Technical Committee must be consulted. The latter will deliver its verdict within 30 days, with no right of appeal.

407. ELECTRONIC

There are no restrictions on electronics except for inertial navigation systems. Only inertial navigation systems available from a catalogue at a public price less than € 7000 ex-VAT are permitted.